

10 D.C. Circuits

10.1 Practical circuits

Candidates should be able to:

- 1 recall and use the circuit symbols shown in section 6 of this syllabus
- 2 draw and interpret circuit diagrams containing the circuit symbols shown in section 6 of this syllabus
- 3 define and use the electromotive force (e.m.f.) of a source as energy transferred per unit charge in driving charge around a complete circuit
- 4 distinguish between e.m.f. and potential difference (p.d.) in terms of energy considerations
- 5 understand the effects of the internal resistance of a source of e.m.f. on the terminal potential difference

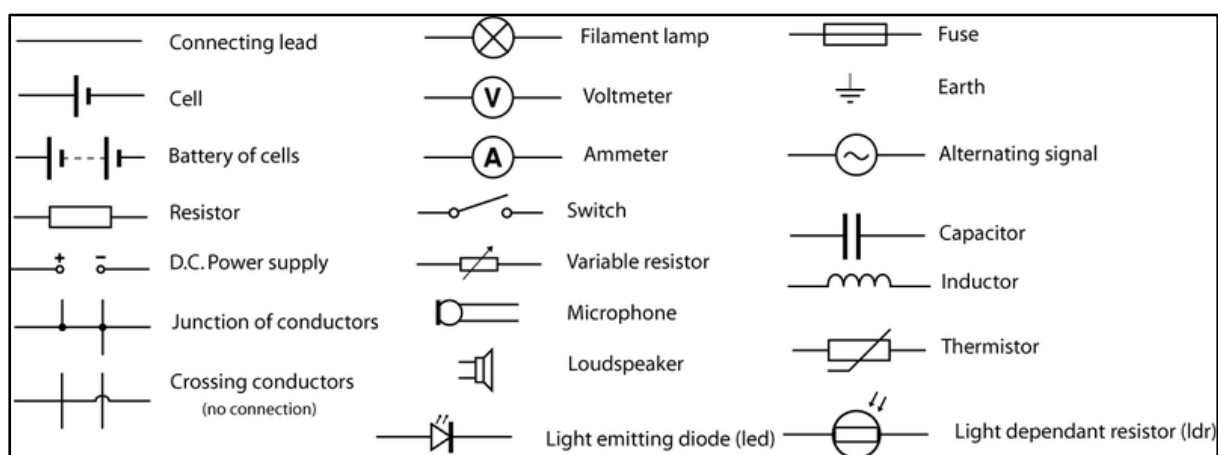

- Candidates must be able to interpret circuit diagrams (refer to IGCSE Chapter 4 Notes (<https://www.senpaicorner.com/course-notes>))
- Welcome to the big confusion which is e.m.f and potential difference aka Volts!
- There is a very small distinction between the both of them so people often get confused.
- As you know (you should at this point...) the potential difference, V is defined as the work done to move a unit of charge across a component (i.e. resistors, capacitors, inductors, wires, etc.).
- Potential difference is measured in volts.
- The definition for electromotive force or e.m.f of a cell is defined as the work done by the cell to drive a unit of charge around a complete circuit.

$$E. m. f, E = \frac{\text{work done by the cell}}{\text{charge}}$$

- The units for e.m.f is also in Volts...
- The difference between the both of them is best illustrated below

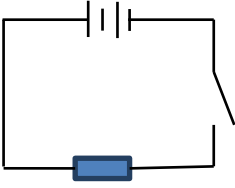
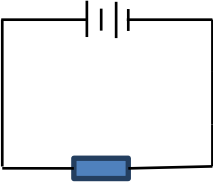
e.m.f	Potential difference
	

- Common sense dictates that if I attach a voltmeter (in parallel) to both battery sources I should get the same reading. Right?
- However in actual experiments, the voltage on the left is bigger than the right.
- The answer to this is due to the internal resistance of the battery.
- Yes you read that right. The battery itself has a resistance, however for the sake of simplicity we have ignored it, up till now....
- The *internal resistance* of battery/ cell is caused by the resistance against the moving charge by the electrolyte in the cell.
- Again lets illustrate this

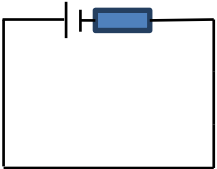
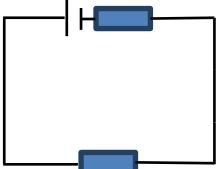
e.m.f	Potential difference
	

- You can see here why e.m.f is always greater than the potential difference.
- This voltage difference is due to the potential difference required to drive the current (I) across the internal resistance (r) and the resistance in the circuit.

$$E = V + Ir$$

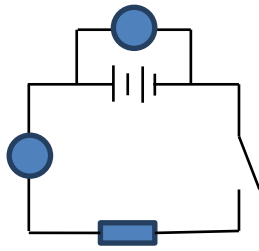

Label the voltmeter and ammeter. The figure above shows an electrical circuit with a $20\ \Omega$ resistor.

When the switch is open the voltmeter gives a reading of 3V .

When the switch is closed, the voltmeter gives a reading of 2.8V .

- i) Calculate the reading of the ammeter when the switch is closed
- ii) The internal resistance of the battery

10.2 Kirchhoff's laws

Candidates should be able to:

- 1 recall Kirchhoff's first law and understand that it is a consequence of conservation of charge
- 2 recall Kirchhoff's second law and understand that it is a consequence of conservation of energy
- 3 derive, using Kirchhoff's laws, a formula for the combined resistance of two or more resistors in series
- 4 use the formula for the combined resistance of two or more resistors in series
- 5 derive, using Kirchhoff's laws, a formula for the combined resistance of two or more resistors in parallel
- 6 use the formula for the combined resistance of two or more resistors in parallel
- 7 use Kirchhoff's laws to solve simple circuit problems

- Kirchhoff's first law states that **the sum of the currents entering a junction always equal the sum of the currents out of the junction**

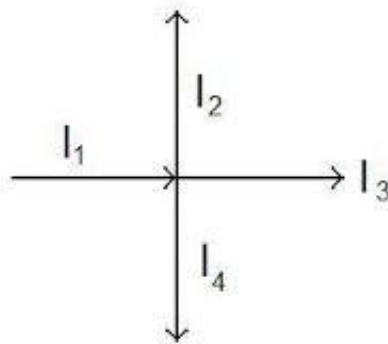

$$I_1 = I_2 + I_3 + I_4$$

- E.g.

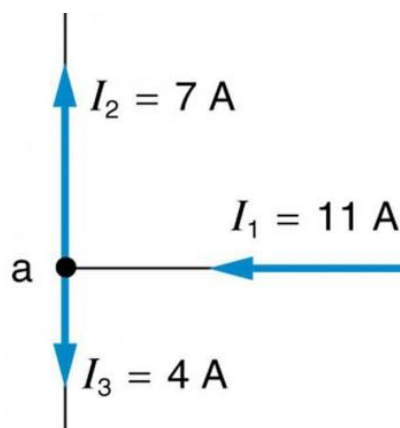

$$I_1 = I_2 + I_3$$

- Kirchoff's second law states that the sum of the e.m.f's in a closed circuit equals the sum of the potential differences.

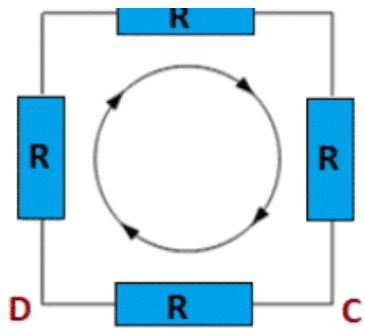

$$V_{AB} + V_{BC} + V_{CD} + V_{DA} = 0$$

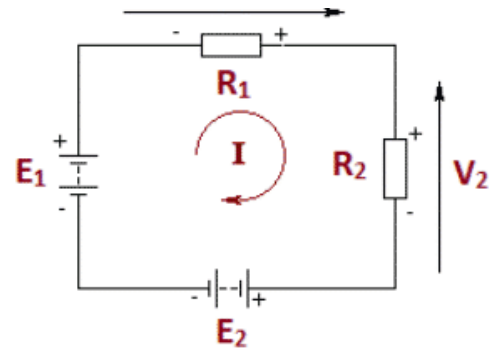

$$E_1 + V_1 - V_2 - E_2 = 0$$

$$E_1 + V_1 = V_2 + E_2$$

- Recall the formulas used to calculate resistance in series and parallel.

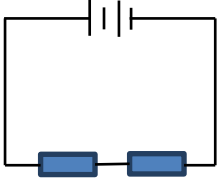
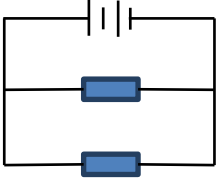
Series	Parallel
	
COMBINED RESISTANCE IN SERIES $R = R_1 + R_2 + R_3 \dots$	COMBINED RESISTANCE IN PARALLEL $\frac{1}{R} = \frac{1}{R_1} + \frac{1}{R_2} + \frac{1}{R_3} \dots$

10.3 Potential dividers

Candidates should be able to:

- 1 understand the principle of a potential divider circuit
- 2 recall and use the principle of the potentiometer as a means of comparing potential differences
- 3 understand the use of a galvanometer in null methods
- 4 explain the use of thermistors and light-dependent resistors in potential dividers to provide a potential difference that is dependent on temperature and light intensity

- According to Kirchoff's Second Law, the potential difference across a power source is divided when two resistors are connected in series.

$$\text{POTENTIAL DIVIDER EQUATION: } V_{\text{out}} = \frac{R_2}{R_1 + R_2} V_{\text{in}}$$

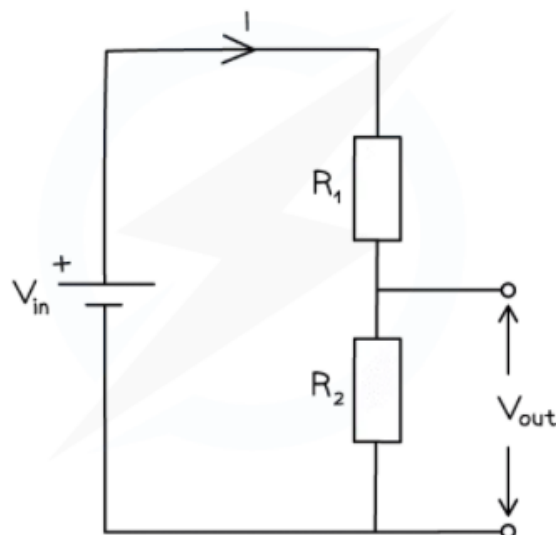

- The larger the resistance the larger the voltage share (the big eater gets more pie!)
- A potential meter is similar to a variable resistor

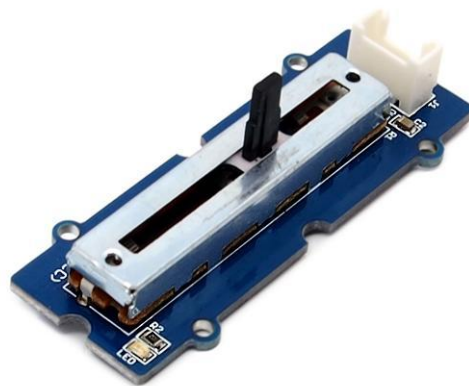
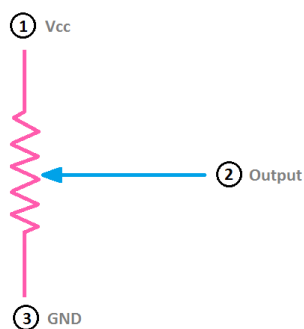

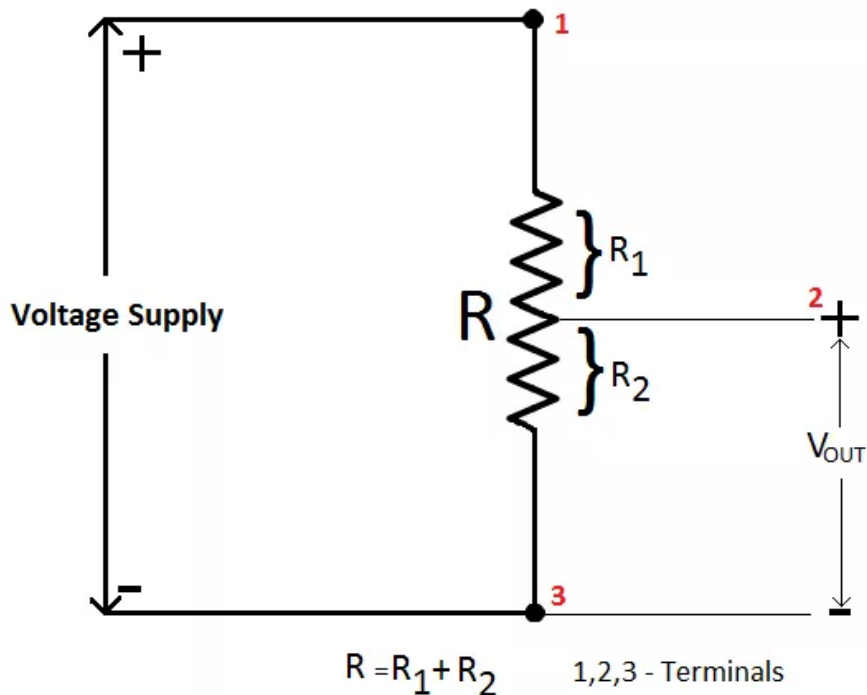

- In the diagram above, the total resistance of the potentiometer is R .
- When the slider is moved it divides R into R_1 and R_2
- If the slider is moved further to the top, R_2 becomes bigger because it becomes longer (big eater!)
- The opposite is true, if the slider is moved further down, R_1 becomes longer and bigger.
- A Galvanometer is a type of ammeter
- It is used to measure current.



- The arrow on a galvanometer deflects depending on the amount of current passing through.

- When the arrow is facing directly upwards, there is no current.
- This is called null deflection.
- Recall that Light Dependent Resistors (LDR) and thermistors are special resistors called sensory resistors.

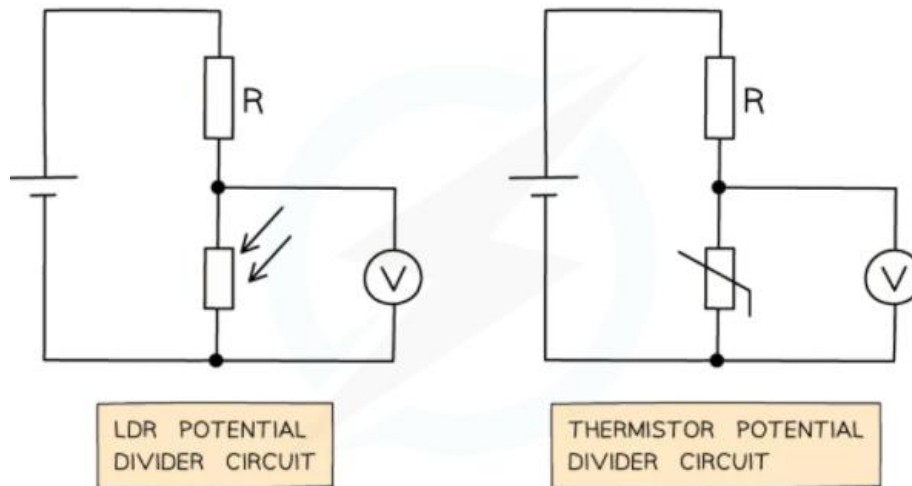

- The higher the light intensity, the lower the resistance of the LDR.
- The hotter the thermistor, the lower the resistance and vice versa.